

AUTOCASE® SC-2
SEMI-AUTOMATIC CASEMAKER

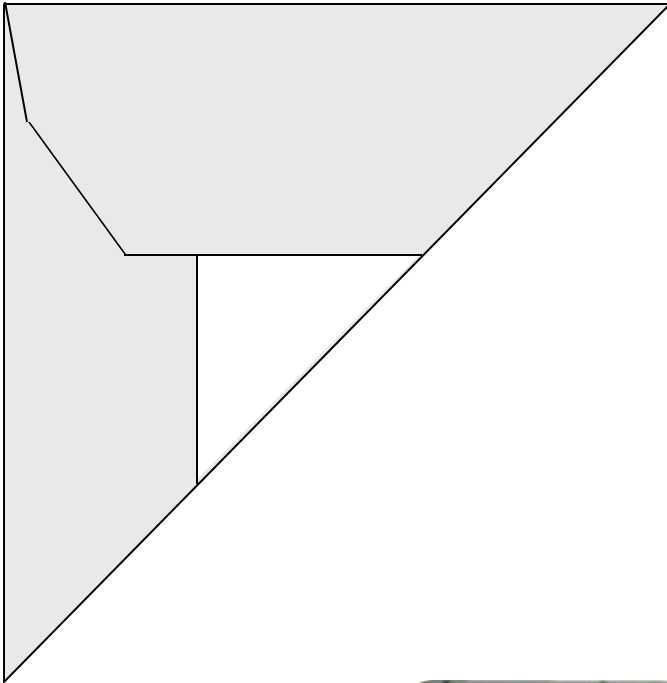

**ZERO SIZE CHANGE + ZERO SCRAP + QUICK TURNAROUND +
SIMPLE OPERATION = PROFIT ON SHORT RUNS**

SIMPLE

With zero size change the Autocase does not require highly skilled operators or maintenance personnel.

RELIABLE

Our proven technology allows our customers to plan their production, day in and day out.

VERSATILE

Our customers produce virtually every turned edge product type using all types of cover material, boards and adhesives in run counts from one cover to five hundred or more.

AFFORDABLE

The SC-2 Autocase offers superior payback compared to alternative methods of automation or manual production based on cost to purchase, labor savings, zero scrap and reliable production output.



The SC-2 Autocase is well suited for running all types of case-made or turned-edge products. Our customers produce book covers, ring binders, menu covers, photo albums and more! A touch of a button switches between Standard (Edition) and Library Corners styles.



The Operator Interface Touchscreen is representative of the advanced technology built into the Autocase and not found on other entry or mid level bindery equipment.

The Touchscreen further exemplifies our commitment to "user" friendly, simple to operate casemakers.



The Corner Trimmer Option automatically trims the Corners from the cover material very accurately during the casemaking operation. This feature streamlines production for On-Demand and Ultra Short Run applications while providing high quality, uniform corners on every cover—even in runs of one!

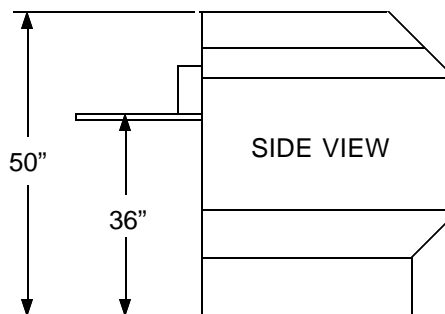
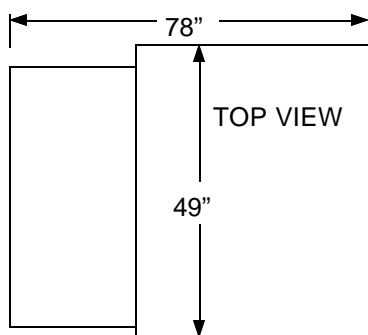

AUTOCASE® SC-2
Semi Automatic Casemaker

Specifications

Operating Speed:

Up to 300 cycles / hour

Make ready time:

Zero

Operators:

One

Operator Interface:

Touchscreen

Case Gage:

Built in

Case Size:

6.62" - 16" Height

*8.62" - 26" Width**

**28" Without Corner Trimmer*

Board Thickness:

.060" - .125"

*Padded board
option available*

Spine Thickness:

up to board thickness

Spine Width:

.25" - 3.25"

Electrical:

230 V, Single phase

50/60 Hz, 15 Amp

Compressed Air:

2cfm @ 80 psi

Machine weight:

Approx. 750 lbs

Specifications are subject to change or revision

Optional Equipment:

Automatic Corner Cutters

Outfeed Conveyor / Video

Assisted Registration System

*GP² Technologies, Inc.
3 Tallwood Drive, Unit 2
Bow, NH 03304*

*Sales Tel. 1-800-435-4975
Sales Fax 1-802-888-4536
Tel. 603-226-0336
Fax 603-226-0444*

*Web: www.gp2tech.com
e-mail: sales@gp2tech.com*